

# Three phase string inverters

ASW LT SERIES

User Manual

ASW15K-LT / 20K-LT



# Solplanet inverter Table of Contents

---

1	Notes on this Manual .....	4
1.1	General Notes .....	4
1.2	Area of Validity .....	4
1.3	Target group .....	4
1.4	Symbols used in this manual .....	5
2	Safety .....	6
2.1	Intended use .....	6
2.2	Important safety information .....	8
2.3	Symbols on the type label .....	10
3	Unpacking .....	11
3.1	Scope of delivery .....	11
3.2	Check for transport damage .....	12
4	Mounting .....	13
4.1	Requirements for mounting .....	13
4.2	Mounting the inverter .....	16
5	Electrical connection .....	20
5.1	Safety .....	20
5.2	Overview of the connection area .....	21
5.3	Electrical connection diagram with a separate DC isolator	21
5.4	AC Connection .....	22
5.4.1	Conditions for the AC connection .....	22
5.4.2	Grid connection .....	26
5.4.3	Additional grounding connection .....	28
5.5	DC connection .....	29

5.5.1	Requirements for the DC connection .....	29
5.5.2	Assembling the DC connectors .....	30
5.5.3	Disassembling the DC connectors.....	32
5.5.4	Connecting the PV Array .....	33
5.6	Communication equipment connection .....	36
5.6.1	Mounting the WiFi/GPRS Stick.....	36
5.6.2	The RS485 connection .....	37
6	Communication .....	39
6.1	System monitoring via WIFI .....	39
6.2	System monitoring via RS485.....	40
6.3	Active power control with Smart meter.....	41
6.4	Active power control via demand response enabling device (DRED) .....	43
6.5	Communication with the third party device.....	43
6.6	Earth fault alarm.....	43
7	Commissioning .....	44
7.1	Electrical check .....	44
7.2	Mechanical check .....	45
7.3	Safety code check.....	45
7.4	Start-up .....	46
8	Display .....	47
8.1	Overview of the control panel.....	47
8.2	LED indicators.....	47
8.2.1.	LED1~LED5 Green power indicator .....	47
8.2.2.	LED6 Yellow communication indicator. ....	48
8.2.3.	LED7 Red fault indicator.....	48
9	Disconnecting the inverter from voltage sources .....	49

10 Technical data.....	51
10.1 DC input data .....	51
10.2 AC output data .....	52
10.3 General data .....	54
10.4 Safety regulations .....	55
11 Troubleshooting .....	55
12 Maintenance .....	60
12.1 Cleaning the contacts of the DC-switch .....	60
12.2 Cleaning the heat sink.....	60
12.3 Maintaining the fan.....	61
13 Recycling and disposal .....	62
14 EU Declaration of Conformity.....	63
15 Warranty .....	63
16 Contact.....	64

# 1 Notes on this Manual

---

## 1.1 General Notes

---

Solplanet inverter is a transformerless solar inverter with two independent MPP trackers. It converts the direct current (DC) from the photovoltaic (PV) arrays to grid-compliant alternating current (AC) and feeds it into the grid.

## 1.2 Area of Validity

---

This manual describes the mounting, installation, commissioning and maintenance of the following Solplanet inverters:

ASW15K-LT

ASW20K-LT

Observe all documentation that accompanies the inverter. Keep them in a convenient place and available at all times.

## 1.3 Target group

---

This manual is for qualified electricians only, who must perform the tasks exactly as described.

All persons installing inverters must be trained and experienced in general safety which must be observed when working on electrical equipment. Installation personnel should also be familiar with local requirements, rules and regulations.

Qualified persons must have the following skills:

- Knowledge of how an inverter works and is operated

- Training in how to deal with the dangers and risks associated with installing, repairing and using electrical devices and installations
- Training in the installation and commissioning of electrical devices
- Knowledge of all applicable laws, standards and directives
- Knowledge of and compliance with this document and all safety information.

#### 1.4 Symbols used in this manual

---

Safety instructions will be highlighted with the following symbols:



DANGER indicates a hazardous situation which, if not be avoided, will result in death or serious injury.



WARNING indicates a hazardous situation which, if not be avoided, can result in death or serious injury.



CAUTION indicates a hazardous situation which, if not be avoided, can result in minor or moderate injury.

## **NOTICE**

NOTICE indicates a situation which, if not be avoided, can result in property damage.



INFORMATION that is important for a specific topic or goal, but is not safety-relevant.

## 2 Safety

---

### 2.1 Intended use

---

1. The inverter converts the direct current from the PV arrays into grid-compliant alternating current.
2. The inverter is suitable for indoor and outdoor use.
3. The inverter must only be operated with PV arrays (PV modules and cabling) of protection class II in accordance with IEC 61730, application class A. Do not connect any sources of energy other than PV modules to the inverter.
4. PV modules with a high capacity to ground must only be used if their coupling capacity does not exceed 7.15 $\mu$ F.
5. When the PV modules are exposed to light, a DC voltage is supplied to the inverter.
6. When designing the PV power plants, ensure that the values comply with the permitted operating range of all components at all times.

7. The inverter must only be used in countries for which it is approved or released by AISWEI and the grid operator.
8. Use this product only in accordance with the information provided in this documentation and with the locally applicable standards and directives. Any other application may cause personal injury or property damage.
9. The type label must remain permanently attached to the product.



## 2.2 Important safety information

### **DANGER**

Danger to life due to electric shock when live components or cables are touched

- All work on the inverter must only be carried out by qualified personnel who have read and fully understood all safety information contained in this manual.
- Do not open the product.
- Children must be supervised to ensure that they do not play with this device.

### **DANGER**

Danger to life due to high voltages of the PV array

When exposed to sunlight, the PV array generates dangerous DC voltage which is present in the DC conductors and the live components of the inverter. Touching the DC conductors or the live components can lead to lethal electric shocks. If you disconnect the DC connectors from the inverter under load, an electric arc may occur leading to electric shock and burns.

- Do not touch non-insulated cable ends.
- Do not touch the DC conductors.
- Do not touch any live components of the inverter.
- Have the inverter mounted, installed and commissioned only by qualified persons with the appropriate skills.
- If an error occurs, have it rectified by qualified persons only.
- Prior to performing any work on the inverter, disconnect it from all voltage sources as described in this document (see Section 9 "Disconnecting the Inverter from Voltage Sources").

## **WARNING**

Risk of injury due to electric shock

Touching an ungrounded PV module or array frame can cause a lethal electric shock.

- connect and ground the PV modules, array frame and electrically conductive surfaces so that there is continuous conduction.

## **CAUTION**

Risk of burns due to hot enclosure parts

Some parts of the enclosure can get hot during operation.

- During operation, do not touch any parts other than the enclosure lid of the inverter.







## **NOTICE**



Damage to the inverter due to electrostatic discharge

Internal components of the inverter can be irreparably damaged by electrostatic discharge.

- Ground yourself before touching any component.

## 2.3 Symbols on the type label

Symbol	Explanation
	Beware of a danger zone This symbol indicates that the product must be additionally grounded if additional grounding or equipotential bonding is required at the installation site.
	Beware of high voltage and operating current The inverter operates at high voltage and current. Work on the inverter must only be carried out by skilled and authorized electricians.
	Beware of hot surfaces The inverter can get hot during operation. Avoid contact during operation.
	WEEE designation Do not dispose of the product together with the household waste but in accordance with the disposal regulations for electronic waste applicable at the installation site.
	CE marking The product complies with the requirements of the applicable EU directives.
	Certification mark The product has been tested by TUV and got the quality certification mark.
	RCM Mark The product complies with the requirements of the applicable Australian standards.

	<p>Capacitors discharge</p> <p>Before opening the covers, the inverter must be disconnected from the grid and PV array. Wait at least 5 minutes to allow the energy storage capacitors to fully discharge.</p>
	<p>Observe the documentation</p> <p>Observe all documentation supplied with the product</p>

### 3 Unpacking

#### 3.1 Scope of delivery

Obj	Description	Quantit
A	Inverter	1 piece
B	Wall bracket	1 piece
C	DC connector	4 pairs
D	Communication connector(optional)	1 piece
E	AC connector	1 piece
F	Screw accessory	1 set
G	Documentation	1 set
H	WiFi/GPRS Stick(optional)	1 piece

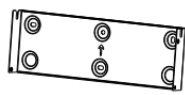

A

B

C

D



E



F



G



H

Please carefully check all the components in the carton. If anything is missing, contact your dealer at once.

### 3.2 Check for transport damage

---

Thoroughly inspect the packaging upon delivery. If you detect any damage to the packaging which indicates the inverter may have been damaged, inform the responsible shipping company immediately. We will be glad to assist you if required.

## 4 Mounting

---

### 4.1 Requirements for mounting

---

#### **DANGER**

Danger to life due to fire or explosion

Despite careful construction, electrical devices can cause fires.

- Do not mount the inverter on flammable construction materials.
- Do not mount the inverter in areas where flammable materials are stored.
- Do not mount the inverter in areas where there is a risk of explosion.

1. Be sure that the inverter is mounted out of the reach of children.
2. Mount the inverter in areas where it cannot be touched inadvertently.
3. Ensure good access to the inverter for installation and possible service.
4. The ambient temperature should be below 40°C to ensure optimal operation.

- Observe the minimum clearances to walls, other inverters, or objects as follows to ensure sufficient heat dissipation.

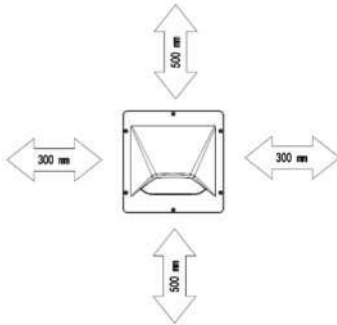

Direction	Min. clearance (mm)
above	500
below	500
sides	300

Clearances for one inverter

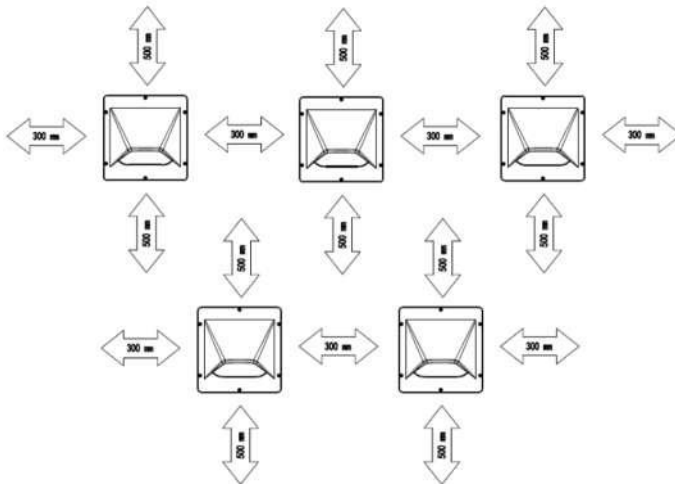

Clearances for multiple inverters

- In order to avoid power reduction caused by overheating, do not mount the inverter in a location that allows long-term exposure to direct sunlight.
- Ensure optimum operation and extend service life, avoid exposing the inverter to direct sunlight, rain and snow.

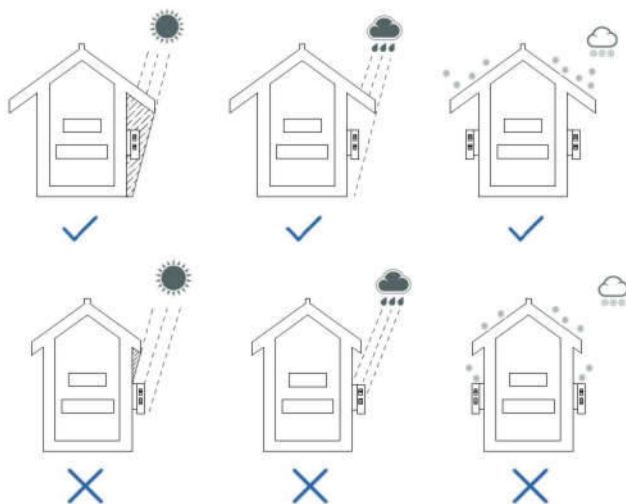

8. The mounting method, location and surface must be suitable for the inverter's weight and dimensions.
9. If mounted in a residential area, we recommend mounting the inverter on a solid surface. Plasterboard and similar materials are not recommended due to audible vibrations when in use.
10. Don't put any objects on the inverter. Do not cover the inverter.
11. Mount the inverter vertically or tilted backward by max.15°.

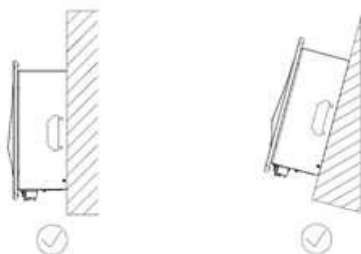



12. Never install the inverter horizontally, or with a forward tilt or with a backward tilt or even with upside down. The horizontal installation can result in damage to the inverter.

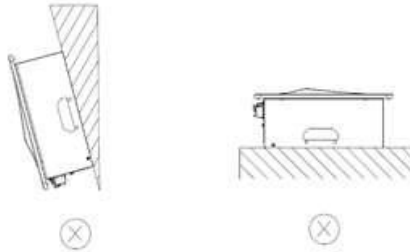

13. Mount the inverter at eye level for easy inspection.

## 4.2 Mounting the inverter

### **⚠ CAUTION**

Risk of injury when lifting the inverter, or if it is dropped  
The weight of Solplanet inverter is max. 25.8 kg. There is risk of injury if the inverter is lifted incorrectly or dropped while being transported or when attaching it to or removing it from the wall bracket.

Mounting procedure:

### **⚠ CAUTION**

Risk of injury due to damaged cables  
There may be power cables or other supply lines (e.g. gas or water) routed in the wall.

- Ensure that no lines are laid in the wall which could be damaged when drilling holes.

1. Use the wall bracket as a drilling template and mark the positions of the drill holes, then drill 3 holes ( $\Phi 10$ ) to a depth about 70mm. During operation, keep the drill vertical to the wall, and hold the drill steady to avoid tilted holes.

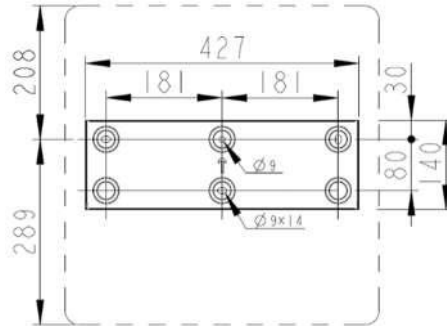

### CAUTION

Risk of injury due to the inverter falls down

If the depth and distance of the holes is not correct, the inverter maybe fall down from the wall.

- Before inserting the wall anchors, measure the depth and distance of the holes.

2. After cleaning the dust and other objects from the holes, place 3 wall anchors into the holes, then attach the wall bracket to the wall using the hexagon head screw delivered with the inverter.

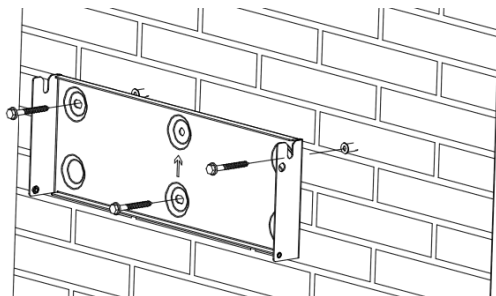

3. Hold the inverter using the handles at the corners, attach the inverter onto the wall bracket tilted slightly downwards.

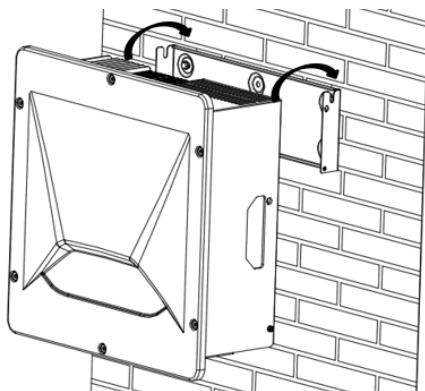

4. Check both sides of the outer fin of the inverter to ensure that it is securely in place.
5. Attach the outer fins of heat sink to both sides of the wall bracket using M4 screws. (screw driver type: PH2, torque: 2.5 Nm).

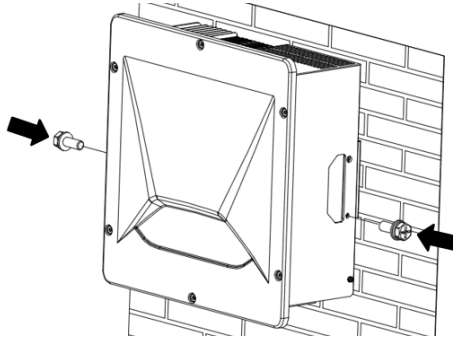

6. There are holes in the side of inverter box, which can be installed with an anti-theft lock according to customer's needs. The anti-theft lock is self provided by the customer.

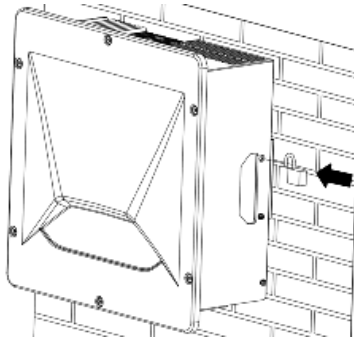

Dismante the inverter in reverse order.

### 5.1 Safety

---

#### **DANGER**

Danger to life due to high voltages of the PV array

When exposed to sunlight, the PV array generates dangerous DC voltage which is present in the DC conductors and the live components of the inverter. Touching the DC conductors or the live components can lead to lethal electric shocks. If you disconnect the DC connectors from the inverter under load, an electric arc may occur leading to electric shock and burns.

- Do not touch non-insulated cable ends.
- Do not touch the DC conductors.
- Do not touch any live components of the inverter.
- Have the inverter mounted, installed and commissioned only by qualified persons with the appropriate skills.
- If an error occurs, have it rectified by qualified persons only.
- Prior to performing any work on the inverter, disconnect it from all voltage sources as described in chapter 9.

#### **WARNING**

Risk of injury due to electric shock

Touching an ungrounded PV module or array frame can cause a lethal electric shock.

- connect and ground the PV modules, array frame and electrically conductive surfaces so that there is continuous conduction.

## 5.2 Overview of the connection area

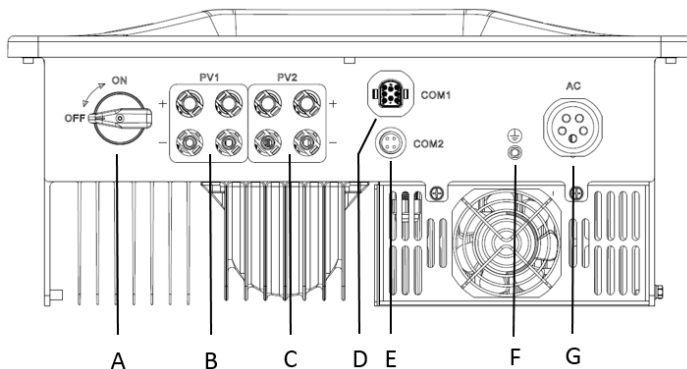

Object	Description
A	DC-switch: switch on or off for PV-load
B	MPP1 input: plug-in connectors to connect the strings
C	MPP2 input: plug-in connectors to connect the strings
D	RS485 and Smart meter(optional): system monitoring
E	WiFi or GPRS (optional): transmit and receive GPRS or Wi-Fi signal
F	Additional grounding screw
G	AC connector: AC output connection

## 5.3 Electrical connection diagram with a separate DC isolator

Local standards or codes may require that a separate DC isolator should be installed next to the inverter. The separate DC isolator

must disconnect each PV string of the inverter so that the entire inverter can be removed if the inverter is faulty. We recommend the following electrical connection:

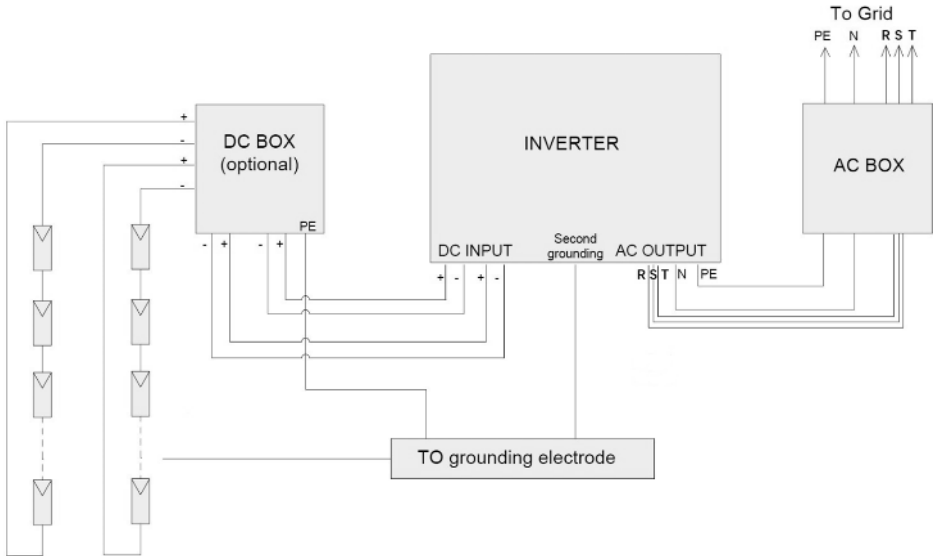

## 5.4 AC Connection

### 5.4.1 Conditions for the AC connection

#### **Cable Requirements**

The grid connection is made using 5 conductors (L1, L2, L3, N, and PE). We recommend the following requirements for stranded copper conductor. Insert the conductor into a suitable ferrule according to DIN46228-4 and crimp the contacts.

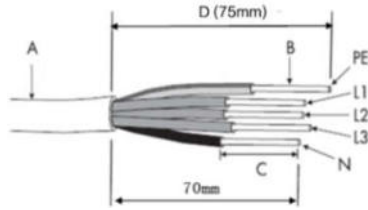

Object	Description	Value
A	External diameter	18...21 mm
B	Conductor cross-section	6...10 mm <sup>2</sup>
C	Stripping length of the insulated conductors	12 mm
D	Stripping length of the AC cable's outer sheath	75 mm
The PE insulated conductor must be 2 mm longer than the L and N conductors		

Larger cross-sections should be used for longer leads.

### Cable Design

The conductor cross-section should be dimensioned to avoid power loss in cables exceeding 1% of rated output power.

The maximum cable lengths relative to the conductor cross-section as follows:

Conductor cross-section	Maximum cable length	
	ASW15K-LT	ASW20K-LT
6mm <sup>2</sup>	30m	24m
8mm <sup>2</sup>	40m	32m
10mm <sup>2</sup>	50 m	40m



The required conductor cross-section depends on the inverter rating, ambient temperature, routing method, cable type, cable losses, valid installation requirements of installation side.

### **Residual current protection**

The product is equipped with an integrated universal current-sensitive residual current monitoring unit inside. The inverter will disconnect immediately from the mains power as soon as fault current with a value exceeding the limit.



If an external residual-current device is required, install a residual-current device which trips at a residual current of 150 mA or higher.

### **Overvoltage category**

The inverter can be used in grids of overvoltage category III or lower in accordance with IEC 60664-1. This means that it can be permanently connected at the grid-connection point in a building. In installations involving long outdoor cable routing, additional measures to reduce overvoltage category IV to overvoltage category III are required.

### **AC circuit breaker**

In PV systems with multiple inverters, protect each inverter with a separate circuit breaker. This will prevent residual voltage being present at the corresponding cable after disconnection.

No consumer load should be applied between AC circuit breaker and the inverter.

The selection of the AC circuit breaker rating depends on the wiring design (wire cross-section area), cable type, wiring

method, ambient temperature, inverter current rating, etc. Derating of the AC circuit breaker rating may be necessary due to self-heating or if exposed to heat.

The maximum output current and the maximum output overcurrent protection of the inverters can be found in section 10 "Technical data".

### **Grounding conductor monitoring**

The inverter is equipped with a grounding conductor monitoring device. This grounding conductor monitoring device detects when there is no grounding conductor connected and disconnects the inverter from the utility grid if this is the case. Depending on the installation site and grid configuration, it may be advisable to deactivate the grounding conductor monitoring. This is necessary, for example, in an IT system if there is no neutral conductor present and you intend to install the inverter between two line conductors. If you are uncertain about this, contact your grid operator or AISWEI.



Safety in accordance with IEC 62109 when the

grounding conductor monitoring is deactivated.

In order to guarantee safety in accordance with IEC 62109 when the grounding conductor monitoring is deactivated, carry out one of the following measures:

- Connect a copper-wire grounding conductor with a cross-section of at least 10 mm<sup>2</sup> to the AC connector bush insert.
- Connect an additional grounding that has at least the same cross-section as the connected grounding conductor to the AC connector bush insert. This prevents touch current in the event of the grounding conductor on the AC connector bush insert failing.

## 5.4.2 Grid connection

---

Procedure:

### **DANGER**

Danger to life due to high voltages in the inverter

Touching the live components can lead to lethal electric shocks.

- Before performing the electrical connection, ensure that the AC circuit-breaker is switched off and cannot be reactivated.

1. Switch off the AC circuit breaker and secure it against reconnection.

## NOTICE

Damage to the inverter due to wrong wiring

If the phase line was connected to PE terminal, the inverter will not function properly.

- Please ensure that the type of the conductors matches the signs of the terminals on the socket element.

2. Guide the swivel nut, the socket element with sealing ring and the adapter over the AC cable. Insert the crimped conductors L1, L2, L3, N and PE into the corresponding terminals and tighten the screw with torque 2.0Nm with the accompanied an Allen key.

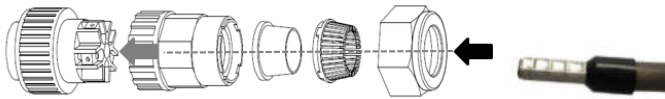

3. Insert the adapter to the socket element, stuff the seal ring into the adapter and tighten the swivel nut.

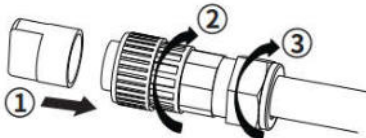

4. Plug the AC connector into the socket for the AC connection and tighten it..

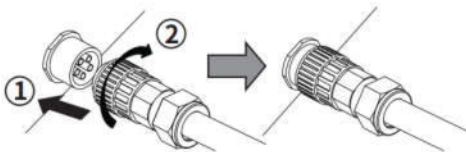

### 5.4.3 Additional grounding connection

---

If additional grounding or equipotential bonding is required locally, you can connect additional grounding to the inverter. This prevents touch current if the grounding conductor on the AC connector fails.

Procedure:

1. Align the terminal lug with protective conductor.
2. Insert the screw through the hole located at the housing and tighten it firmly (screw driver type: PH2, torque: 2.5Nm).

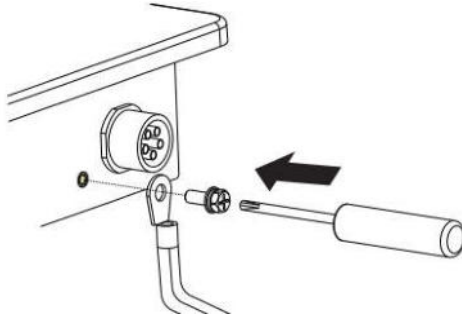

Grounding parts information:

Object	Explanation
M5 screw	Screwdrivertype: PH2, torque: 2.5Nm
OT terminal lug	Customer provided, type: M5
Grounding cable	Copperconductorcross-section: 6-10mm <sup>2</sup>

## 5.5 DC connection

---

### **DANGER**

Danger to life due to high voltages in the inverter  
Touching the live components can lead to lethal electric shocks.

- Before connecting the PV generator, ensure that the DC-switch is switched off and that it cannot be reactivated.
- Do not disconnect the DC connectors under load.

### 5.5.1 Requirements for the DC connection

---

Requirements for the PV modules of a string:

- PV modules of the connected string must be the same type, identical alignment and identical tilt.
- The thresholds for the input voltage and the input current of the inverter must be adhered to (see Section 10.1 "DC input data").
- On the coldest day based on statistical records, the open-circuit voltage of the PV array must never exceed the maximum input voltage of the inverter.
- The connection cables of the PV modules must be provided with the connectors
- The positive connection cables of the PV modules must be fitted with the positive DC connectors. The negative connection cables of the PV modules must be provided with the negative DC connectors.

## 5.5.2 Assembling the DC connectors

### **⚠ DANGER**

Danger to life due to high voltages on DC conductors  
When exposed to sunlight, the PV array generates dangerous DC voltage which is present in the DC conductors. Touching the DC conductors can lead to lethal electric shocks.

- Cover the PV modules.
- Do not touch the DC conductors.

Assemble the DC connectors as described below. Be sure to observe the correct polarity. The DC connectors are marked with the symbols "+" and "-".

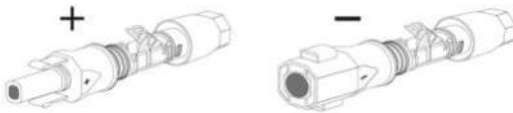

Cable requirements:

The cable must be of type PV1-F, UL-ZKLA or USE2 and comply with the following properties:

- External diameter: 5-8mm
- Conductor cross-section: 2.5-6mm<sup>2</sup>
- Qty single wires: minimum 7
- Nominal voltage: minimum 1000V

Procedure:

1. Strip 12 mm of the cable insulation.

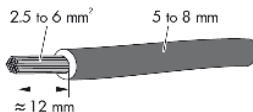

2. Route the stripped cable all the way into the DC connector.

Ensure that the stripped cable and the DC connector have the same polarity.



3. Press the clamping bracket down until it audibly snaps into place.

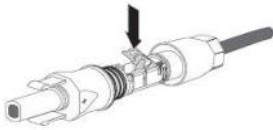

4. Ensure that the cable is correctly positioned:

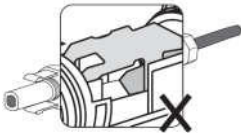
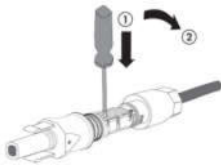
Result	Measure
<p>If the stranded wires are visible in the chamber of the clamping bracket, the cable is correctly positioned.</p> 	<ul style="list-style-type: none"> <li>•Proceed to step 5.</li> </ul>
<p>If the stranded wires are not visible in the chamber, the cable is not correctly positioned.</p> 	<ul style="list-style-type: none"> <li>•Release the clamping bracket. To do so, insert a flat-blade screwdriver (blade width: 3.5 mm) into the clamping bracket and lever it open.</li> </ul>  <ul style="list-style-type: none"> <li>•Remove the cable and go back to step 2.</li> </ul>



5. Push the swivel nut up to the thread and tighten (SW15, torque: 2 Nm).

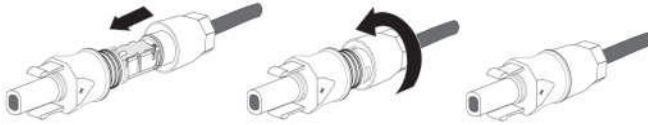

### 5.5.3 Disassembling the DC connectors

#### **DANGER**

Danger to life due to high voltages on DC conductors

When exposed to sunlight, the PV array generates dangerous DC voltage which is present in the DC conductors. Touching the DC conductors can lead to lethal electric shocks.

- Cover the PV modules.
- Do not touch the DC conductors.

Procedure:

1. Set the DC-Switch of the inverter to position “OFF”.
2. Unscrew the swivel nut.



3. To release the DC connector, insert a flat-blade screwdriver (blade width: 3.5 mm) into the side catch mechanism and lever open.



- Carefully pull the DC connector apart.



- Release the clamping bracket. To do so, insert a flat-blade screwdriver (blade width: 3.5 mm) into the clamping bracket and lever it open.



- Remove the cable.



## 5.5.4 Connecting the PV Array

### **NOTICE**

Destruction of the inverter due to overvoltage

If the voltage of the strings exceeds the maximum DC input voltage of the inverter, it can be destroyed due to overvoltage. All warranty claims become void.

- Do not connect strings with an open-circuit voltage greater than the maximum DC input voltage of the inverter.
- Check the design of the PV system

Procedure:

- Ensure that the individual AC circuit breaker is switched off and secure it against reconnection.
- Ensure that the DC-switch is switched off and secure it against reconnection.

3. Ensure that there is no ground fault in the PV strings.
4. Check whether the DC connector has the correct polarity. If the DC connector fits with a DC cable having the wrong polarity, the DC connector must be reassembled again. The DC cable must always have the same polarity as the DC connector.
5. Ensure that the open-circuit voltage of the PV strings does not exceed the maximum DC input voltage of the inverter.
6. Connect the assembled DC connectors to the inverter until they audibly snap into place.

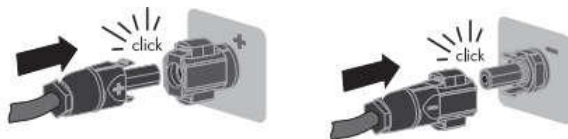

## NOTICE

Damage to the inverter due to moisture and dust penetration  
Seal the unused DC inputs with sealing plugs so that moisture and dust cannot penetrate the Inverter.

- Make sure all DC connectors are securely sealed.

7. Insert the sealing plugs provided into the DC plug connectors which are not used.

- For unused DC connectors, push down the clamping bracket and push the swivel nut up to the thread.

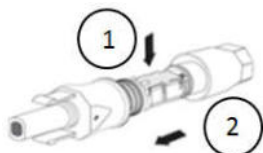

- Insert the sealing plug into the DC connector.

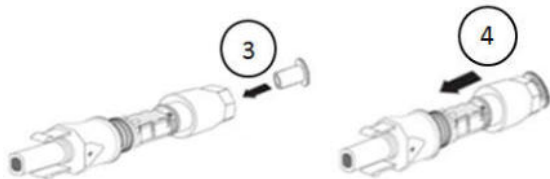

- Tighten the DC connector (torque: 2 Nm).



- Insert the DC connectors with sealing plugs into the corresponding DC inputs on the inverter.

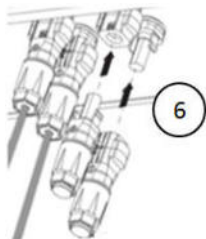

## 5.6 Communication equipment connection

---

### 5.6.1 Mounting the WiFi/GPRS Stick

---

#### **NOTICE**

Damage to the inverter due to electrostatic discharge  
Internal components of the inverter can be irreparably  
damaged by electrostatic discharge.

- Ground yourself before touching any component.

When the system uses WiFi or GPRS Stick monitoring,  
WiFi/GPRS Stick should be connected to COM2 socket.

Procedure:

1. Take out the Stick included in the scope of delivery.
2. Attach the Stick to the connection port COM2 in place and tighten the nut into the port by hand. Make sure the stick is securely connected and the label on the modular can be visible.

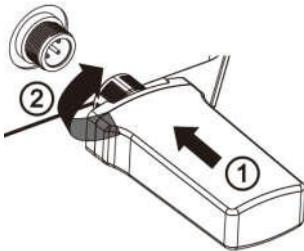

## 5.6.2 The RS485 connection

### **NOTICE**

The inverter can be destroyed by wrong communication wiring

- Internal components of the inverter can be irreparably damaged due to incorrect wiring between the power wire and signal wire. All the warranty claim will be invalid.
- Please check the wiring of the RJ45 connector before crimping the contact.

This inverter is equipped with two RS485 interfaces for multipoint communication.

Pinout detail of the RS485 interface on the inverter as follows

Pin1 ----- VCC	
Pin2 / Pin5 ----- RS485A	
Pin3 / Pin6 ----- RS485B	
Pin4 ----- GND	
Pin7 ----- Shielding grounding	

The network cable meeting the EIA/TIA 568A or 568B standard must be UV resistant if it is to be used outdoors.

Cable requirement :

- Shielding wire
- CAT-5E or higher
- UV-resistant for outdoor use
- RS485 cable maximum length 1000m

Connect the communication cable procedure:

1. Cable requirements are as follows. Insert the conductor into a suitable ferrule acc. to DIN 46228-4 and crimp the contacts.

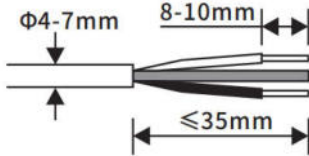

2. Guide the swivel nut, the socket element with sealing ring and the adapter over the cable. Insert the crimped conductors into the corresponding terminals and tighten the screw with torque 0.2Nm. Screwdriver type: PH0

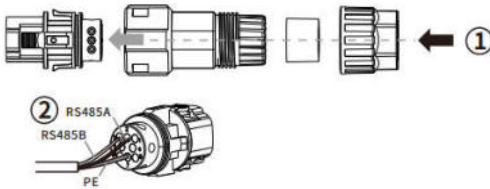

If required, install the delivered terminal resistance.



3. Insert the adapter to the socket element, stuff the seal ring into the adapter and tighten the swivel nut. Plug the communication connector into the socket on the inverter.

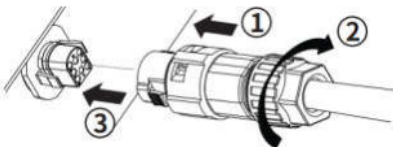

Disassemble the communication cable in reverse order.

## 6 Communication

### 6.1 System monitoring via WIFI

User can monitor the inverter through the external WiFi stick with WLAN module. The connection diagram between the inverter and internet with a RS485 connection is shown as following two pictures, both two methods are available. Please note that each WiFi stick can only connect up to 5 inverters in method1.

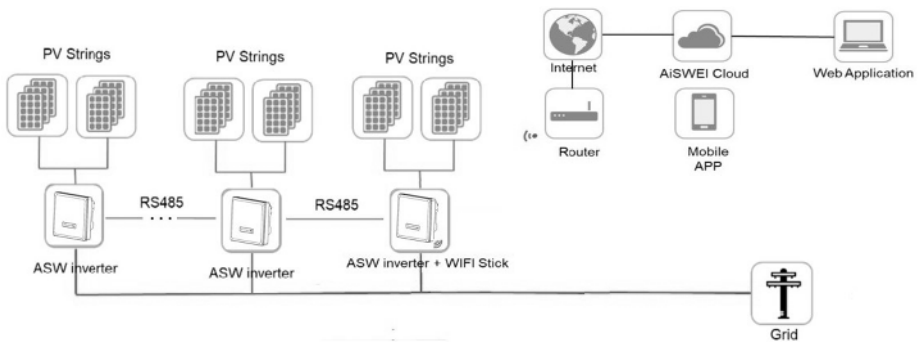

Method 1 only one inverter with the WiFi Stick, the other inverter be connected through the RS 485 cable.

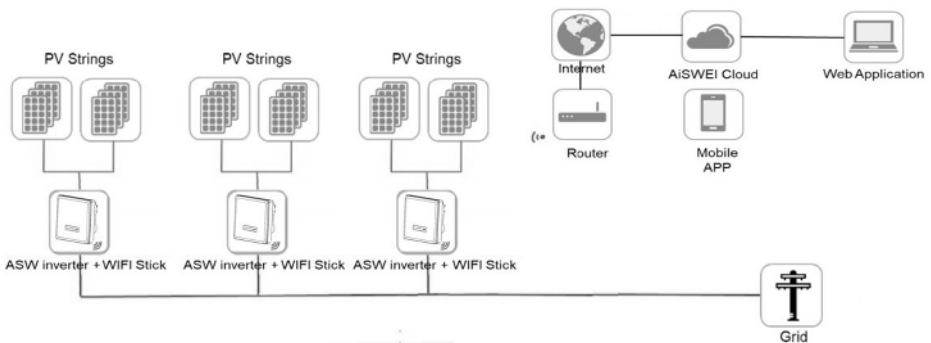



Mehod 2 every inverter with WiFi Stick, Every inverter can connect to internet.

As shown above, we offer a remote monitoring platform called “AiSWEI cloud”. You can install the “AiSWEI cloud” application on a smart phone using Android or iOS operating system. You can also visit the website ( [www.solplanet.net](http://www.solplanet.net) ) for system information. And download the user manual for the AISWEI Cloud Web or AISWEI Cloud APP.

## 6.2 System monitoring via RS485

---

This inverter is equipped with RJ45 interfaces for multipoint communication.

One AiCom connects inverters via an RS485 bus. The overall length of the network cable should not exceed 1,000 m. The monitoring system layout for inverters is as follows.

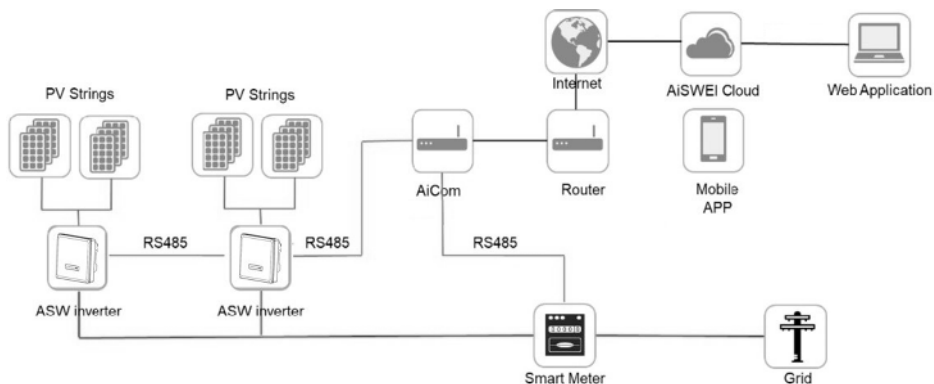

The AiCom connects to the inverter via the RJ45 interface, and it connects to the router via Ethernet. User can monitor the inverter through the external Aicom with Ethernet module (optional).



Possible reason of communication failure due to closed port

- The AiCom uses port #1883 and #80 communicates with the AiSWEIcloud. Both two ports must be opened, or else the AiCom cannot connect to the AiSWEIcloud and upload data.



Possible reason of communication failure due to

DHCP

- The router needs to support DHCP services if the AiCom use the DHCP function.

For more information, you can visit the website ( [www.solplanet.net](http://www.solplanet.net) ) and download the user manual for the AiCom.

### 6.3 Active power control with Smart meter

---

The inverter can control activepower output via connecting smart meter, following picture is the system connection mode through WiFi stick.

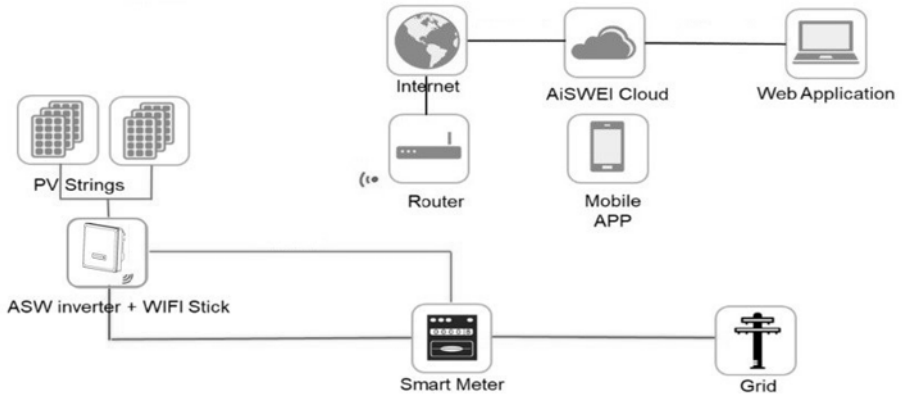

However, If you choose the AiCom instead of the WiFi stick, the inverter should connect to AiCom by RS485, and also the smart meter connect to the AiCom, the connection description please refer to the picture in section 6.2.

Smart meter as above SDM120-Modbus connecting method and setting baud rate method for modbus please refer to its user manual.



Possible reason of communication failure due to incorrect connection

- WiFi stick only support single inverter to do active power control.
- The overall length of the cable from AiCom to smart meter is 100m.

The active power limit can be set on “AiSWEI cloud” application, the details can be found in the user manual for the AISWEI Cloud APP.

## 6.4 Active power control via demand response enabling device (DRED)

---



### DRMs application description

- Only applicable to AS/NZS4777.2:2015.
- DRM0, DRM5, DRM6, DRM7, DRM8 are available.

If DRMs support is required, the inverter should be used in conjunction with AiCom. the Demand Response Enabling Device (DRED) can be conneted to the DRED port on AiCom via RS485 cable. You can vist the website [www. solplanet.net](http://www.solplanet.net) for more information and download the user manual for the AiCom.

## 6.5 Communication with the third party device

---

Solplanet inverters can also connect with one third party device instead of Aicom or WiFi stick, the communication protocol is modbus. For more information, please contact the Service.

## 6.6 Earth fault alarm

---

This inverter complies with IEC 62109-2 clause 13.9 for earth fault alarm monitoring. If an Earth Fault Alarm occurs, the red color LED indicator will light up. At the same time, the error code 38 will be sent to the AISWEI Cloud. (This function is only available in Australia and New Zealand)

## 7 Commissioning

---

### 7.1 Electrical check

---

Carry out the main electrical checks as follows:

- ① Check the PE connection with a multimeter: check that the inverter's exposed metal surface has a grounding connection.

#### **WARNING**

Danger to life due to the presence of DC-Voltage

Touching the live conductors can lead to lethal electric shocks.

- Only touch the insulation of the PV array cables.
  - Do not touch parts of the sub-structure and frame of the PV array which isn't grounded.
  - Wear personal protective equipment such as insulating gloves.
- ② Check the DC voltage values: make sure that the DC voltage of the strings does not exceed the permitted limits.
  - ③ Check the polarity of the DC voltage: make sure the DC voltage has the correct polarity.
  - ④ Check the PV generator's insulation to ground with a multimeter: make sure that insulation resistance to ground is greater than 1MΩ.

## **WARNING**

Danger to life due to the presence of AC-Voltage  
Touching the live conductors can lead to lethal electric shocks.

- Only touch the insulation of the AC cables.
- Wear personal protective equipment such as insulating gloves.

- ⑤ Check the grid voltage: check that the grid voltage at the point of connection of the inverter is within the permitted range.

### 7.2 Mechanical check

---

Carry out the main mechanical checks to ensure the inverter is waterproof as follows:

- ① Make sure the inverter has been correctly mounted with wall bracket.
- ② Make sure the cover has been correctly mounted.
- ③ Make sure the communication cable and AC connector have been correctly wired and tightened.

### 7.3 Safety code check

---

Choose suitable safety code according to the location of installation. please visit website ( [www.solplanet.net](http://www.solplanet.net) ) and download the AISWEI Cloud APP manual for detailed information, you can find the Safety Code Setting Guide in an event where an installer needs to set the country code manually.



The Solplanet's inverters comply with local safety code when leaving the factory.

## 7.4 Start-up

---

After finishing the electrical and mechanical checks, switch on the miniature circuit-breaker and DC-switch in turn. Once the DC input voltage is sufficiently high and the grid-connection conditions are met, the inverter will start operation automatically. Usually, there are three states during operation:

- 1) **Waiting:** When the initial voltage of the strings is greater than the minimum DC input voltage but lower than the start-up DC input voltage, the inverter is waiting for sufficient DC input voltage and cannot feed power into the grid.
- 2) **Checking:** When the initial voltage of the strings exceeds the start-up DC input voltage, the inverter will check feeding conditions at once. If there is anything wrong during checking, the inverter will switch to the "Fault" mode.
- 3) **Normal:** After checking, the inverter will switch to "Normal" state and feed power into the grid.

During periods of low radiation, the inverter may continuously start up and shut down. This is due to insufficient power generated by the PV array.

If this fault occurs often, please call service.



If the inverter is in “Fault” mode, refer to chapter 11 “Troubleshooting”.

## 8 Display

---

### 8.1 Overview of the control panel

---

The inverter is equipped with a display panel. You can view the running status.

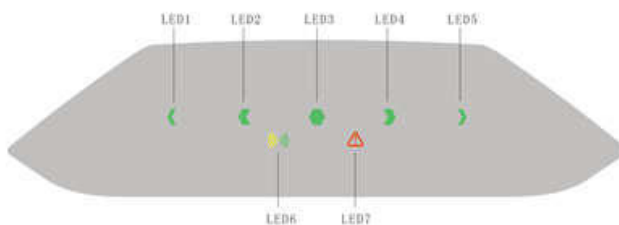

### 8.2 LED indicators

---

The inverter is equipped with three LED indicators including “green”, “yellow” and “red” which provide information about the various operating status as follows.

#### 8.2.1. LED1~LED5 Green power indicator

---

When the output power is 0 to 20% rated power, the LED1 bright. When the output power reaches 20% to 40% , LED1 and LED2 bright. When the output power reaches 40% to 60%, LED1 to LED3 bright, output power reaches 60% to 80% rated power LED1 to LED4 bright. When the output power reaches 80% to 100% rated power when LED1 to LED5 are fully bright.



When the DC input and AC input meet the requirements of grid-connected, inverter into the ready-to-grid state, the above five LEDs into the horse light mode, according to the following mode cycle: LED1→LED2→LED3→LED4→LED5, time interval 1s.

### 8.2.2. LED6 Yellow communication indicator.

---

The light flashes when the inverter communicates with other devices e.g. Aicom, Solarlog etc. Also, flashes during firmware update through RS485.

### 8.2.3. LED7 Red fault indicator.

---

The light is on when the invert is faulty or when external conditions cannot be grid-connected or when it is working improperly.

## 9 Disconnecting the inverter from voltage sources

---

Before performing any work on the inverter, disconnect it from all voltage sources as described in this section. Always adhere strictly to the given sequence.

1. Disconnect AC circuit breaker and secure against reconnection.
2. Disconnect the DC-switch and secure against reconnection.
3. Use a current probe to ensure that no current is present in the DC cables.

### **DANGER**

Danger to life due to electric shock when touching exposed DC conductors or DC plug contacts if the DC connectors are damaged or loose

The DC connectors can break or become damaged, become free of the DC cables, or no longer be connected correctly if the DC connectors are released and disconnected incorrectly. This can result in the DC conductors or DC plug contacts being exposed. Touching live DC conductors or DC plug connectors will result in death or serious injury due to electric shock.

- Wear insulated gloves and use insulated tools when working on the DC connectors.
- Ensure that the DC connectors are in perfect condition and that none of the DC conductors or DC plug contacts are exposed.
- Carefully release and remove the DC connectors as described in the following.

4. Release and disconnect all DC connectors. To do so, insert a flat-blade screwdriver or an angled screwdriver (blade width: 3.5 mm) into one of the side and pull the DC connectors straight out. Do not pull on the cable.

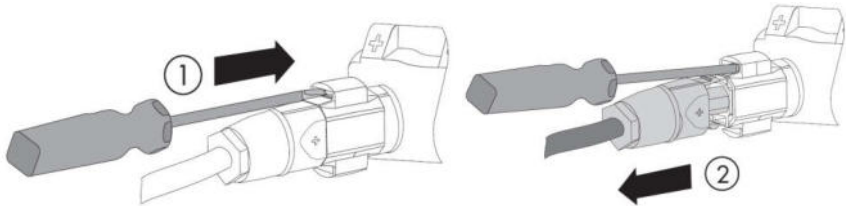

5. Release and disconnect the AC connector. Rotate the socket element counter-clockwise to open.

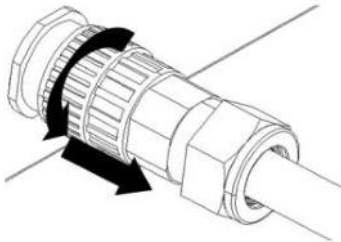

6. Wait until all LEDs and the display have gone out.

## 10 Technical data

### 10.1 DC input data

Type	ASW20K-LT	ASW15K-LT
Max. PV modules power(STC)	26000Wp STC	19500Wp STC
Max. input voltage/ Rated input voltage	1000 V/640V	
MPP voltage range	150 ~ 950 V	
Full load MPP voltage range	500~800V	
Intitial feed-in voltage	188V	
Min input voltage	150V	
Max. DC input current	24A/24A	24A/12A
I <sub>sc</sub> PV, absolute max.	36A/36A	36A/18A
MAX. backfeed current	0A	
Number of MPP trackers	2	
Strings per MPP tracker	2/2	
Overtoltage category in accordance with IEC 62109-1	II	

(1) When the DC input voltage is greater than 1020V, the inverter will alarm an error.

(2) When the DC input voltage is lower than 995V, the inverter starts self-checking.

## 10.2 AC output data

Type	ASW20K-LT	ASW15K-LT
Max. output apparent power	20000VA	15000 VA
Rated AC Voltage <sup>(1)</sup>	3/N/PE, 220/380 V, 230/400 V, 240/415 V	
AC voltage range	180 V ~295V	
Rated AC Frequency <sup>(2)</sup>	50 Hz/ 60 Hz	
Operating range at AC power frequency 50 Hz	45 Hz to 55Hz	
Operating range at AC power frequency 60 Hz	55 Hz to 65Hz	
Max. continuous output current	3×32 A	3×25A
MAX. output fault current	43A	
MAX. output overcurrent protection	50A	
Inrush current	10A@250us	
Adjustable displacement power factor	0.8 overexcited to 0.8 underexcited	
Harmonic distortion (THD) at the rated power	< 3%	
Night-time power loss	<1 W	
Standby power loss	<12 W	
Overvoltage category in accordance with IEC62109-1	III	

(1) The AC voltage range depends on the local safety standards and rules.

(2) The AC frequency range depends on the local safety standards and rules.

## 10.3 General data

Type	ASW20K-LT	ASW15K-LT
Net weight	25.8 Kg	
Dimensions(L×W×D)	490×497×212.5 mm	
Mounting environment	Indoor and Outdoor	
Mounting recommendation	Wall mounting bracket	
Operating temperature range	-25...+60°C	
Max. permissible value for relative humidity ( non-condensing )	100%	
Max. operating altitude above mean sea level	3000m	
Ingress protection	IP65 according to IEC60529	
Climatic category	4K4H	
Protection class	I ( in accordance with IEC 62103)	
Topology	Transformerless	
Feed-in phases	3	
Cooling concept	FAN-Cooling	
Noise emission (typical)	<45 dB(A)	
Display	LED	
Communication interfaces	4G/WiFi /RS485 (optional)	
Radio technology	WLAN 802.11 b / g / n	
Radio spectrum	WLAN 2.4 GHz with 2412MHz – 2472MHz band	
Antenna gain	2dBi	

## 10.4 Safety regulations

Type	ASW20K-LT	ASW15K-LT
Internal	Integrated	
DC insulation	Integrated	
DC feed-in	Integrated	
Grid monitoring	Integrated	
DC isolator	Integrated	
DC reverse polarity protection	Integrated	
Residual current	Integrated (in accordance with EN	
Islanding	Integrated (Three-phase monitoring)	
EMC immunity	EN61000-6-1	
	EN61000-6-2	
	ETSI EN301489-17	
EMC emission	EN61000-6-1	
	EN61000-6-2	
	ETSI EN301489-1	
Utility interference	EN61000-3-11, EN61000-3-12	
RF emission	EN300328	

## 11 Troubleshooting

When the PV system does not operate normally, we recommend the following solutions for quick troubleshooting. If an error occurs, the red LED will light up. There will have "Event Messages" display in the monitor tools. The corresponding corrective measures are as follows:



Object	Error code	Corrective measures
Presumable Fault	E33	<ul style="list-style-type: none"> <li>• Check the grid frequency and observe how often major fluctuations occur.</li> </ul> <p>If this fault is caused by frequent fluctuations, try to modify the operating parameters after informing the grid operator first.</p>
	E34	<ul style="list-style-type: none"> <li>• Check the grid voltage and grid connection on inverter.</li> <li>• Check the grid voltage at the point of connection of inverter.</li> </ul> <p>If the grid voltage is outside the permissible range due to local grid conditions, try to modify the values of the monitored operational limits after informing the electric utility company first. If the grid voltage lies within the permitted range and this fault still occurs, please call service.</p>
	E35	<ul style="list-style-type: none"> <li>• Check the fuse and the triggering of the circuit breaker in the distribution box.</li> <li>• Check the grid voltage, grid usability.</li> <li>• Check the AC cable, grid connection on the inverter.</li> </ul> <p>If this fault is still being shown, contact the service.</p>

Presumable Fault	E36	<ul style="list-style-type: none"> <li>• Make sure the grounding connection of the inverter is reliable.</li> <li>• Make a visual inspection of all PV cables and modules.</li> </ul> <p>If this fault is still shown, contact the service.</p>
	E37	<ul style="list-style-type: none"> <li>• Check the open-circuit voltages of the strings and make sure it is below the maximum DC input voltage of the inverter.</li> </ul> <p>If the input voltage lies within the permitted range and the fault still occurs, please call service.</p>
	E38	<ul style="list-style-type: none"> <li>• Check the PV array's insulation to ground and make sure that the insulation resistance to ground is greater than 1 MOhm. Otherwise, make a visual inspection of all PV cables and modules.</li> <li>• Make sure the grounding connection of the inverter is reliable.</li> </ul> <p>If this fault occurs often, contact the service.</p>
	E40	<ul style="list-style-type: none"> <li>• Check whether the airflow to the heat sink is obstructed.</li> <li>• Check whether the ambient temperature around the inverter is too high.</li> </ul>
	E46	<ul style="list-style-type: none"> <li>• Check whether the open circuit voltage of each photovoltaic group is <math>\geq 1020V</math>.</li> </ul>

		If the open circuit voltage of each pv group is less than 995V and this fault still exists, please contact the service personnel.
	E48	<ul style="list-style-type: none"> <li>• Check whether the electric supply is abnormal.</li> </ul> <p>If the electric supply is normal and this fault still exists, please contact the service personnel.</p>
	E56 E57 E58	<ul style="list-style-type: none"> <li>• Disconnect the inverter from the grid and the PV array and reconnect after 3 minutes.</li> </ul> <p>If this fault is still being shown, contact the service.</p>
	E61 E62	Check the DRED device communication or operation.
Permanent Fault  Permanent Fault	E01 E03 E05 E07 E08 E10	<ul style="list-style-type: none"> <li>• Disconnect the inverter from the utility grid and the PV array and reconnect it after LED turn off.</li> </ul> <p>If this fault is still being displayed, contact the service.</p>

Warning code	Warning message
31	PV1 input over voltage
32	PV2 input over voltage
34	PV1 input over current-software
35	PV1 input over current-hardware
36	PV2 input over current-software
37	PV2 input over current-hardware
40	BUS over voltage-software
42	BUS voltage unbalance(for three phase inverter)
44	Grid voltage over instant
45	Output over current-software
46	Output over current-hardware
47	Anti-islanding
55	IGBT CE Voltage saturation
150	PV1-SPD Fault
156	Inter Fan abnormal
163	GFCI Redundancy check
165	Ground connect warning
166	CPU self-test --register abnormal
167	CPU self-test --RAM abnormal
174	Low Air Temperature

## 12 Maintenance

---

Normally, the inverter needs no maintenance or calibration. Regularly inspect the inverter and the cables for visible damage. Disconnect the inverter from all power sources before cleaning. Clean the housing, cover and display with a soft cloth. Ensure the heatsink at the rear of the inverter cover is not covered.

### 12.1 Cleaning the contacts of the DC-switch

---

Clean the contacts of the DC-switch once per year. Perform cleaning by cycling the switch to “1” and “0” positions 5 times. The DC-switch is located at the lower left of the housing.

### 12.2 Cleaning the heat sink

---

#### CAUTION

Risk injury due to hot heat sink

The heat sink may exceed 70°C during operation.

- Do not touch the heatsink during operation.
- Wait approx. 30 minutes before cleaning until the heatsink has cooled down.

Clean the heat sink with pressurized air or a soft brush. Do not use aggressive chemicals, cleaning solvents or strong detergents.

For proper function and long service life, ensure free air circulation around the heatsink.

## 12.3 Maintaining the fan

### CAUTION

#### **Risk of injury due to hot heat sink!**

- The heat sink may exceed 70°C during operation. Do not touch the heat sink during operation.
- Wait approx. 30 minutes before maintenance until the heat sink has cooled down.

### CAUTION

#### **Damage to the fan due to compressed air!**

- Clean the fan only with a soft brush, a paint brush, or a damp cloth.

This device is equipped with a fan located on the right bottom side. If the fan does not run normally or makes any unusual noise, clean the fan and replace the broken fan . To do so, disconnect the inverter from all power sources, and wait approx. 30 minutes until the inverter has cooled down. Unscrew the fan bracket(Screwdriver type: PH2) and remove the fans out of the inverter by pressing on the cable locking hooks of the fan .Then the fan can be cleaned using a soft cloth or a brush or be replaced. After maintenance, Reassemble the fan back and tighten 3 screws on the fan bracket with a screwdriver(Torque: 2.5Nm).

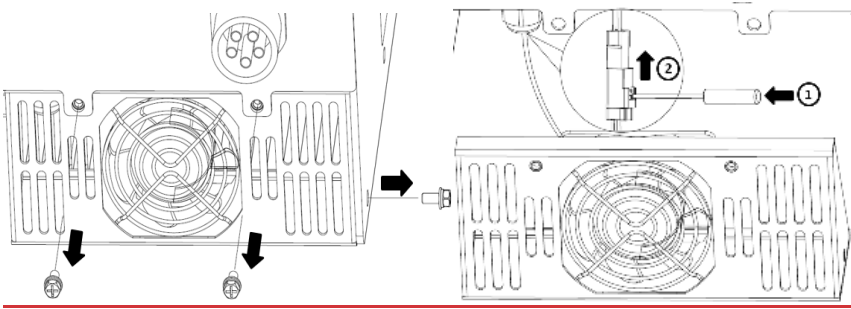

### 13 Recycling and disposal

Dispose of the packaging and replaced parts according to the rules at the installation site where the device is installed.



Do not dispose the inverter with normal domestic waste.

#### **i** WEEE designation

Do not dispose of the product together with the household waste but in accordance with the disposal regulations for electronic waste applicable at the installation site.

## 14 EU Declaration of Conformity

---

within the scope of the EU directives

- Electromagnetic compatibility 2014/30/EU (L 96/79-29, 2014) (EMC).
- Low Voltage Directive 2014/35/EU.(L 96/357-374, March 29, 2014)(LVD).
- Radio Equipment Directive 2014/53/EU (L 153/62-106. May 22. 2014) (RED)



AISWEI New Energy Technology (Jiangsu) Co., Ltd. confirms herewith that the inverters described in this document are in compliance with the fundamental requirements and other relevant provisions of the above mentioned directives.

The entire EU Declaration of Conformity can be found at [www.solplanet.net](http://www.solplanet.net).

## 15 Warranty

---

The factory warranty card is enclosed with the package, please keep well the factory warranty card. Warranty terms and conditions can be downloaded at [www.solplanet.net](http://www.solplanet.net), if required. When the customer needs warranty service during the warranty period, the customer must provide a copy of the invoice, factory warranty card, and ensure the type label of the inverter is legible. If these conditions are not met, AISWEI has the right to refuse to provide with the relevant warranty service.



## 16 Contact

---

If you have any technical problems concerning our products, please contact Aiswei service. We require the following information in order to provide you with the necessary assistance:

- Inverter device type
- Inverter serial number
- Type and number of connected PV modules
- Error code
- Mounting location
- Warranty card

### Aiswei Service Contact

Our regional services contact information can be found at:

<https://solplanet.net/contact-us/>

AISWEI New Energy Technology (Jiangsu) Co., Ltd.

Tel.: +86 512 6937 0998

Fax: +86 512 6937 3159

[Web: www.solplanet.net](http://www.solplanet.net)

Factory add.: No.588 Gangxing Road, Yangzhong Jiangsu,  
China

Headquarters add.: Building 9, No.198 Xiangyang Road, Suzhou  
215011, China

---

